

THE INFORMATION CONTAINED IN THIS DRAWING IS THE SOLE PROPERTY OF QED ENVIRONMENTAL. ANY REPRODUCTION IN PART OR WHOLE WITHOUT THE WRITTEN PERMISSION OF QED ENVIRONMENTAL IS PROHIBITED.

### REVISIONS

REV.	DESCRIPTION	ECO #	DRAWN BY	CHECKED BY	DATE
-	RELEASED FOR PRODUCTION	3952	TR	-	8/21/2017

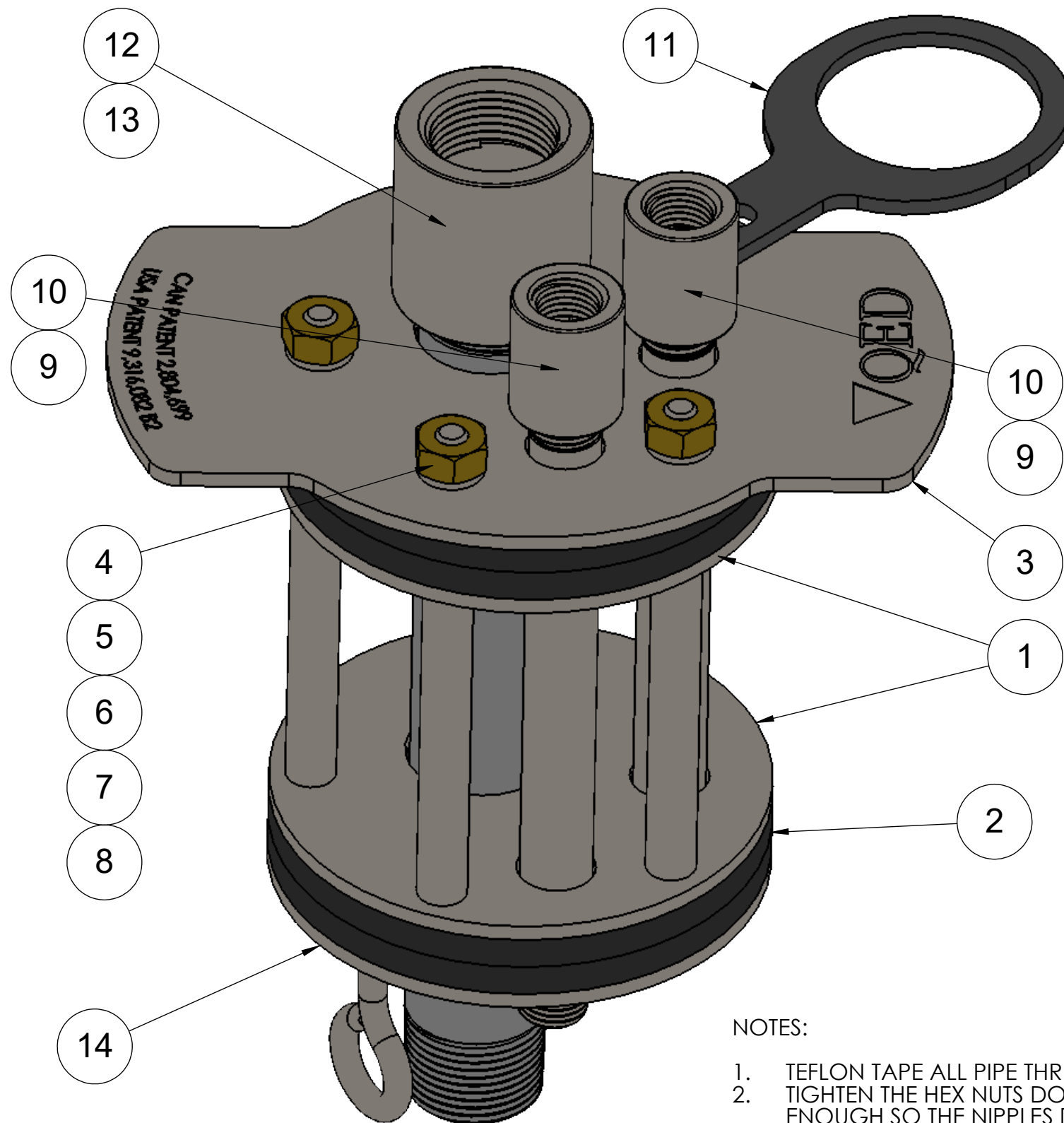

ITEM	PART #	DESCRIPTION	QTY.
1	403-1-CP	CLAMP PLATE	2
2	403-1-GA	RUBBER GASKET	5
3	403-1-TP	TOP PLATE	1
4	N25	Hex Nut 1/4-20 Brass	5
5	CB25	Carriage Bolt	5
6	RW25	Retaining Washer	5
7	S25	Spacer	5
8	W25	Narrow Flat Washer 1/4	5
9	P-SS40-25-TBE	1/4in NPT-M Port	2
10	COUP-SS-25	1/4" SS FULL COUPLING	2
11	39040	BRACKET, FILTER/REG. NAW 3000	1
12	COUP-SS-75	3/4in NPT Coupling	1
13	41389	NIPPLE, 3/4 X 8 LONG, SS	1
14	41412	CLAMP PLATE AND SUSPENSION HOOK WELD	1

**NOTES:**

1. TEFLON TAPE ALL PIPE THREADED JOINTS
2. TIGHTEN THE HEX NUTS DOWN JUST ENOUGH SO THE NIPPLES DO NOT MOVE.
3. RETAINING WASHER IS PLACED BETWEEN THE BOTTOM PLATE AND THE LOWEST RUBBER GASKET.

UNLESS OTHERWISE SPECIFIED, DIMENSIONS ARE IN INCHES AND INCLUDE PLATING REMOVE ALL BURRS	DRAWN BY	DATE	 <p><b>2355 BISHOP CIRCLE W, DEXTER, MI. 48130</b></p>
	TR	08-21-17	
TOLERANCES	CHECKED BY	DATE	
XX +/- .01 FRACT +/- 1/64	-	-	<p><b>TITLE</b> 4" WELL CAP ASSEMBLY, SCH 80 PIPE, 3 PORTS</p>
XXX +/- .005 ANGLES +/- 1/2	APPROVED BY	DATE	
OTHER TOLERANCES AS SPECIFIED	-	-	<p>DWG. NO. 403-80-BASE</p>
NEXT ASSY	-	MATERIAL	SCALE 1:4
USED ON	-	FINISH	SHEET 1 OF 1
			REV. A