

THE INFORMATION CONTAINED IN THIS DRAWING IS THE SOLE PROPERTY OF QED ENVIRONMENTAL. ANY REPRODUCTION IN PART OR WHOLE WITHOUT THE WRITTEN PERMISSION OF QED ENVIRONMENTAL IS PROHIBITED.

REVISIONS

REV.	DESCRIPTION	ECO #	DRAWN BY	CHECKED BY	DATE
-	RELEASED FOR PRODUCTION	3952	TR	-	8/10/2017

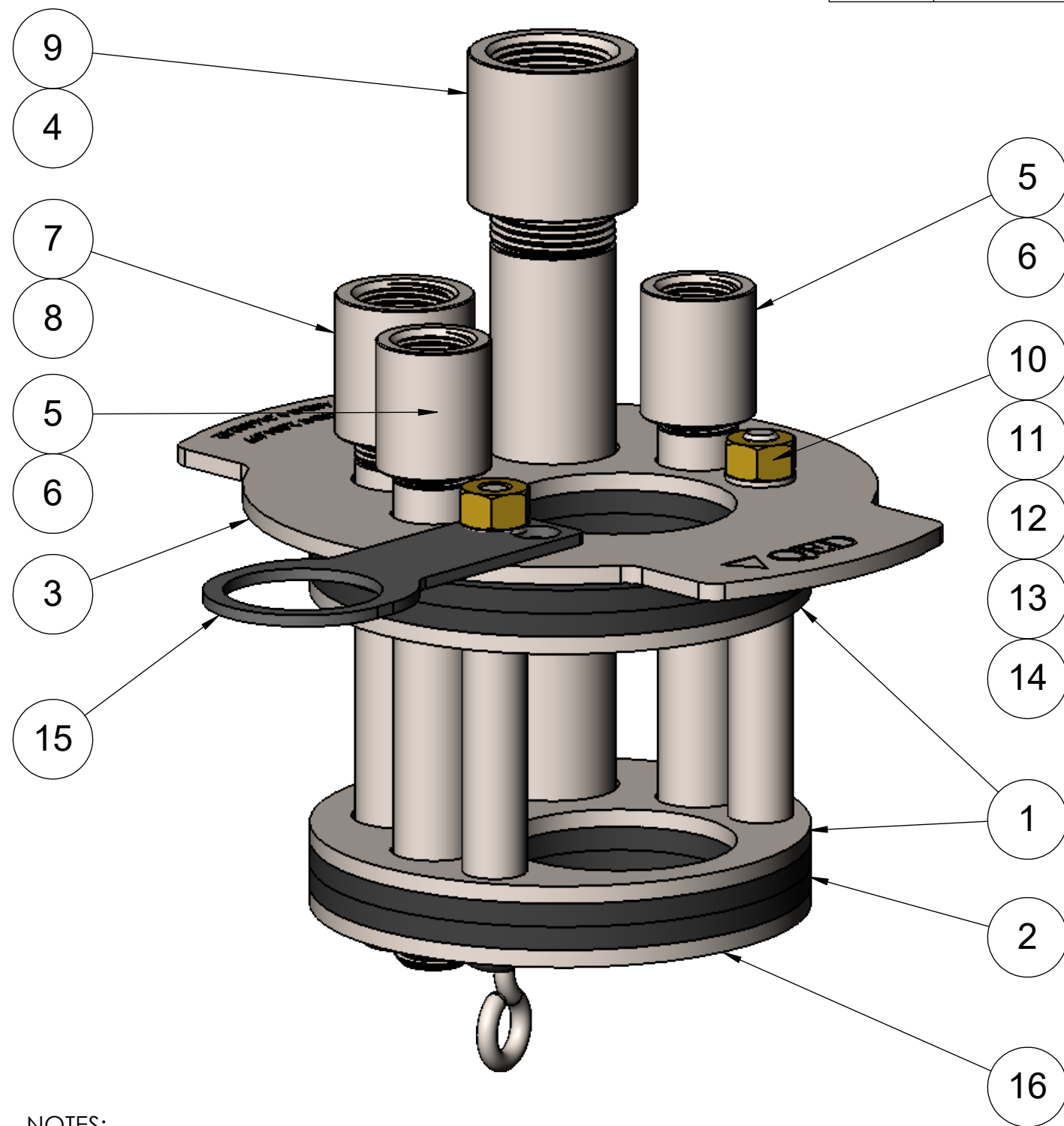

ITEM	PART #	DESCRIPTION	QTY.
1	DR11-625-3-CP R1	Clamp Plate	2
2	DR11-625-3-GA R1	Rubber Gasket	5
3	DR11-625-3-TP R1	Top Plate	1
4	P-SS40-100-TBE	1in NPT-M Port, 8in Length	1
5	COUP-SS-50	150 LBS 304 SS 1/2" COUPLING	2
6	P-SS40-50-TBE	1/2in NPT-M Port	2
7	COUP-SS-75	3/4in NPT Coupling	1
8	P-SS40-75-TBE	3/4in NPT-M Port	1
9	COUP-SS-100	1in NPT Coupling	1
10	N38	Hex Nut 3/8-16 Brass	3
11	W38	Flat Washer 3/8	3
12	CB38	Carriage Bolt	3
13	S38	Spacer	3
14	RW38	Retaining Washer	3
15	41406	BRACKET, FILTER/REG. NAW 3000	1
16	41413	6" DR11 CLAMP PLATE AND SUSPENSION HOOK WELD	1

NOTES:

1. TEFLON TAPE ALL PIPE THREADED JOINTS
2. TIGHTEN THE HEX NUTS DOWN JUST ENOUGH SO THE NIPPLES DO NOT MOVE.
3. RETAINING WASHER IS PLACED BETWEEN THE BOTTOM PLATE AND THE LOWEST RUBBER GASKET.

UNLESS OTHERWISE SPECIFIED, DIMENSIONS ARE IN INCHES AND INCLUDE PLATING REMOVE ALL BURRS	DRAWN BY	TR	DATE	8/10/17	 <p>2355 BISHOP CIRCLE W, DEXTER, MI. 48130</p> <p>TITLE 6" BASE CAP ASSY WTH 2 IN GAS PORT FOR DR11 WELLS</p>	
	CHECKED BY	-	DATE	-		
	APPROVED BY	-	DATE	-		
TOLERANCES XX +/- .01 FRACT +/- 1/64 XXX +/- .005 ANGLES +/- 1/2 OTHER TOLERANCES AS SPECIFIED	NEXT ASSY	-	MATERIAL	-	DWG. NO. 625-DR11-BASE	
USED ON	-	FINISH	-	SCALE 1:4	SHEET 1 OF 1	REV. A