

THE INFORMATION CONTAINED IN THIS DRAWING IS THE SOLE PROPERTY OF Q.E.D. ENVIRONMENTAL ANY REPRODUCTION IN PART OR WHOLE WITHOUT THE WRITTEN PERMISSION OF Q.E.D. ENVIRONMENTAL IS PROHIBITED.

REVISIONS

REV.	DESCRIPTION	ECO #	DRAWN BY	CHECKED BY	DATE
-	INITIAL RELEASE	4026	TR	MTM	1/30/2018

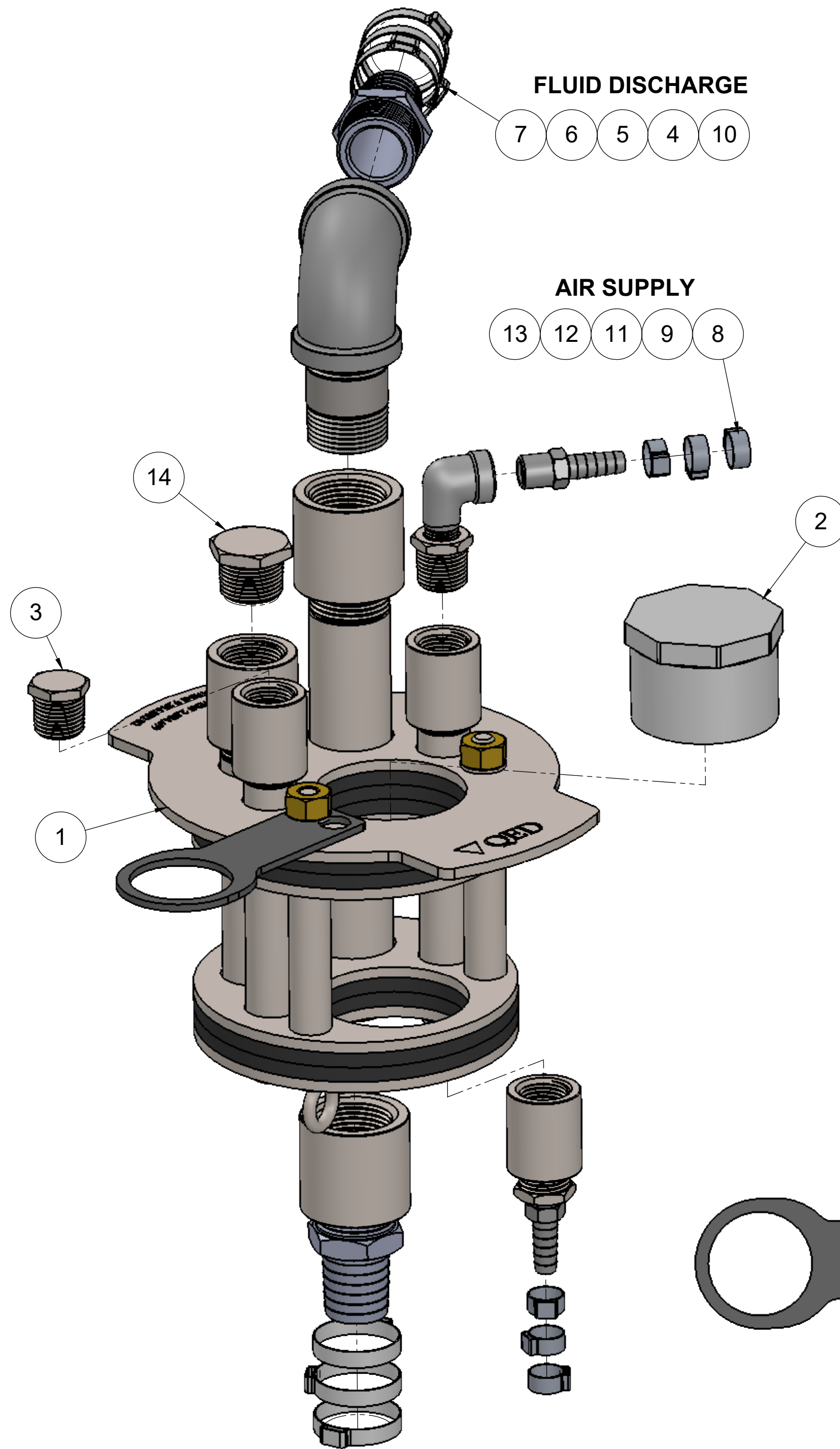

ITEM	PART #	DESCRIPTION	QTY.
1	625-DR11-BASE	6" DR11 WELL BASE CAP	1
2	204372	PLUG 2" SPG SCH 40 PVC	1
3	PLUG-SS-50	1/2 IN NPT-M PLUG	1
4	810083	NIPPLE 1" X 2" LG	1
5	37092	ELBOW 1 FPT 304SS	1
6	205583	BARB 1" x 1" MPT S.S.	2
7	39360	CLAMP, 1-EAR FOR 1-1/4" TUBING	6
8	35209	CLAMP 13.8-706R (FOR 1/2" TUBING)	6
9	38875	BARB 3/8" x 1/4" MPT AIR SUPPLY S.S.	2
10	COUP-SS-100	1in NPT Coupling	1
11	204981	STREET ELBOW 1/4 304 SS	1
12	RB-SS-50-25	1/2 TO 1/4 SS BUSHING	2
13	COUP-SS-50	150 LBS 304 SS 1/2" COUPLING	1
14	PLUG-SS-75	3/4in NPT-M Plug	1

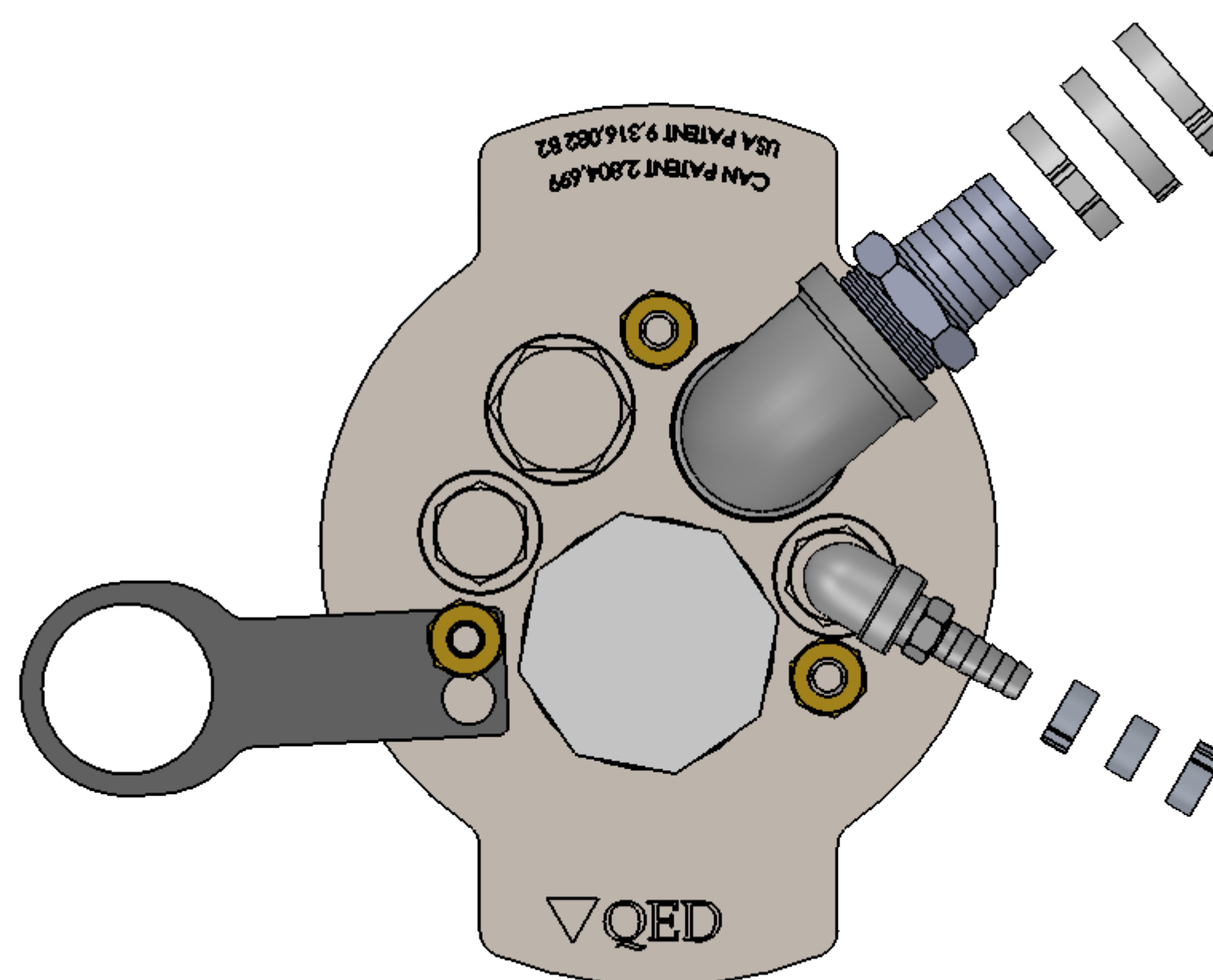

AS ASSEMBLED

NOTE:

1. TEFLON TAPE ALL PIPE THREADED JOINTS.
2. CLAMPS ARE PLACED IN A PLASTIC BAG AND SHIP TOGETHER

UNLESS OTHERWISE SPECIFIED, DIMENSIONS ARE IN INCHES AND INCLUDE PLATING REMOVE ALL BURRS	DRAWN BY	DATE	 2355 BISHOP CIRCLE W, DEXTER, MI. 48130
	TR	01-30-18	
TOLERANCES XX +/- .01 FRACT +/- 1/64 XXX +/- .005 ANGLES +/- 1/2 OTHER TOLERANCES AS SPECIFIED	CHECKED BY	DATE	TITLE
	MTM	3/9/18	
NEXT ASSY -	APPROVED BY	DATE	DWG. NO. AP306208
USED ON -	MATERIAL -	FINISH -	SCALE 1:4 SHEET 1 OF 1