

THE INFORMATION CONTAINED IN THIS DRAWING IS THE SOLE PROPERTY OF Q.E.D. ENVIRONMENTAL ANY REPRODUCTION IN PART OR WHOLE WITHOUT THE WRITTEN PERMISSION OF Q.E.D. ENVIRONMENTAL IS PROHIBITED.

REVISIONS

REV.	DESCRIPTION	ECO #	DRAWN BY	CHECKED BY	DATE
-	INITIAL RELEASE	4020	TR	-	1/24/2018
A	39227 WAS 202868	4311	MTM	-	10/24/2018

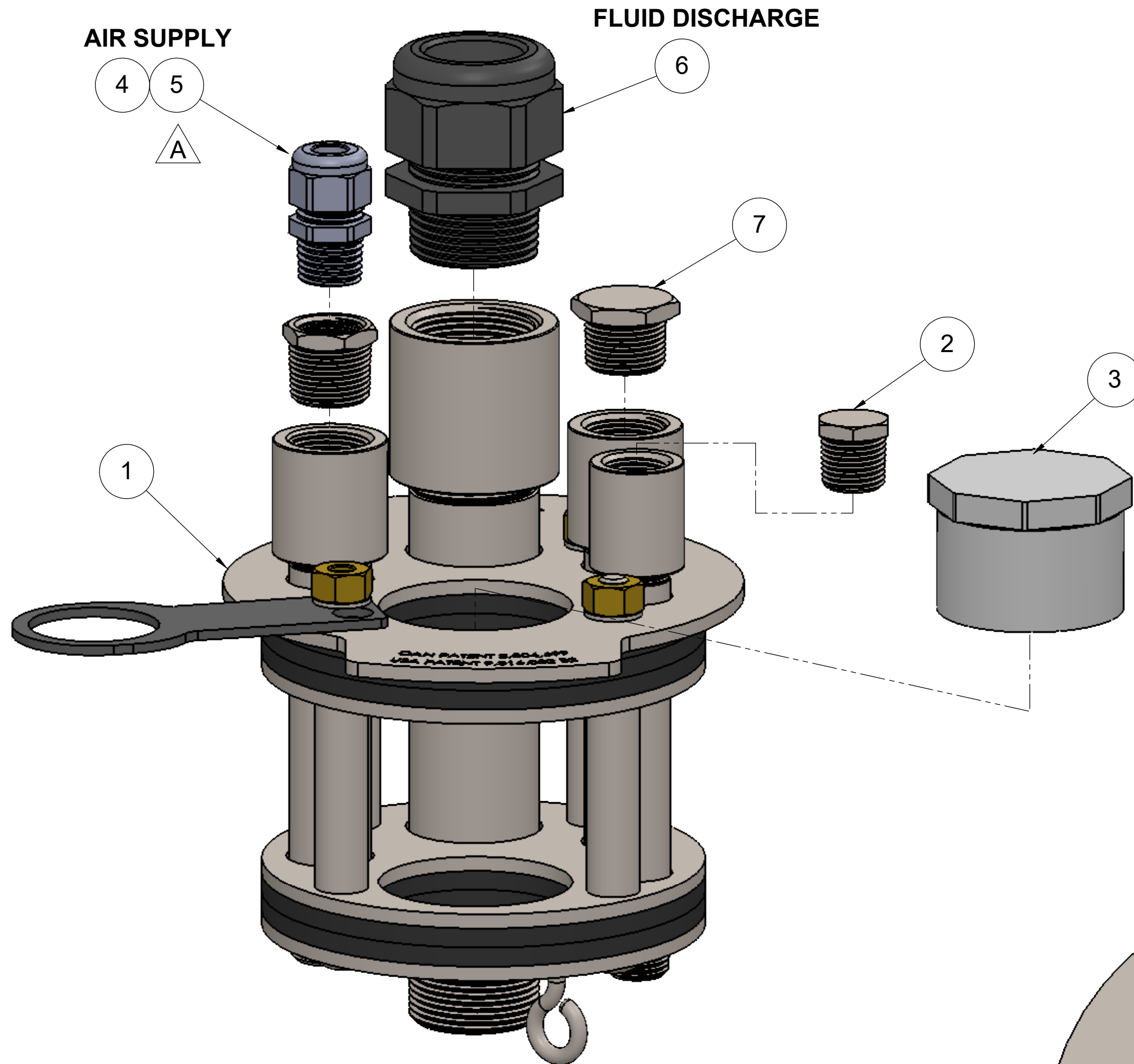

ITEM	PART #	DESCRIPTION	QTY.	
1	625-80-BASE	6" SCH 80 OR DR17 WELL BASE CAP	1	
2	PLUG-SS-50	1/2 IN NPT-M PLUG	1	
3	204372	PLUG 2" SPG SCH 40 PVC	1	
4	RB-SS-75-50	3/4-1/2in Reducer Bushing	1	
A	5	39227	COMP .230 -.546 X 1/2" MPT LT NYLON	1
6	CF-NY-125-100	Cable Gland 1-1/4in	1	
7	PLUG-SS-75	3/4in NPT-M Plug	1	

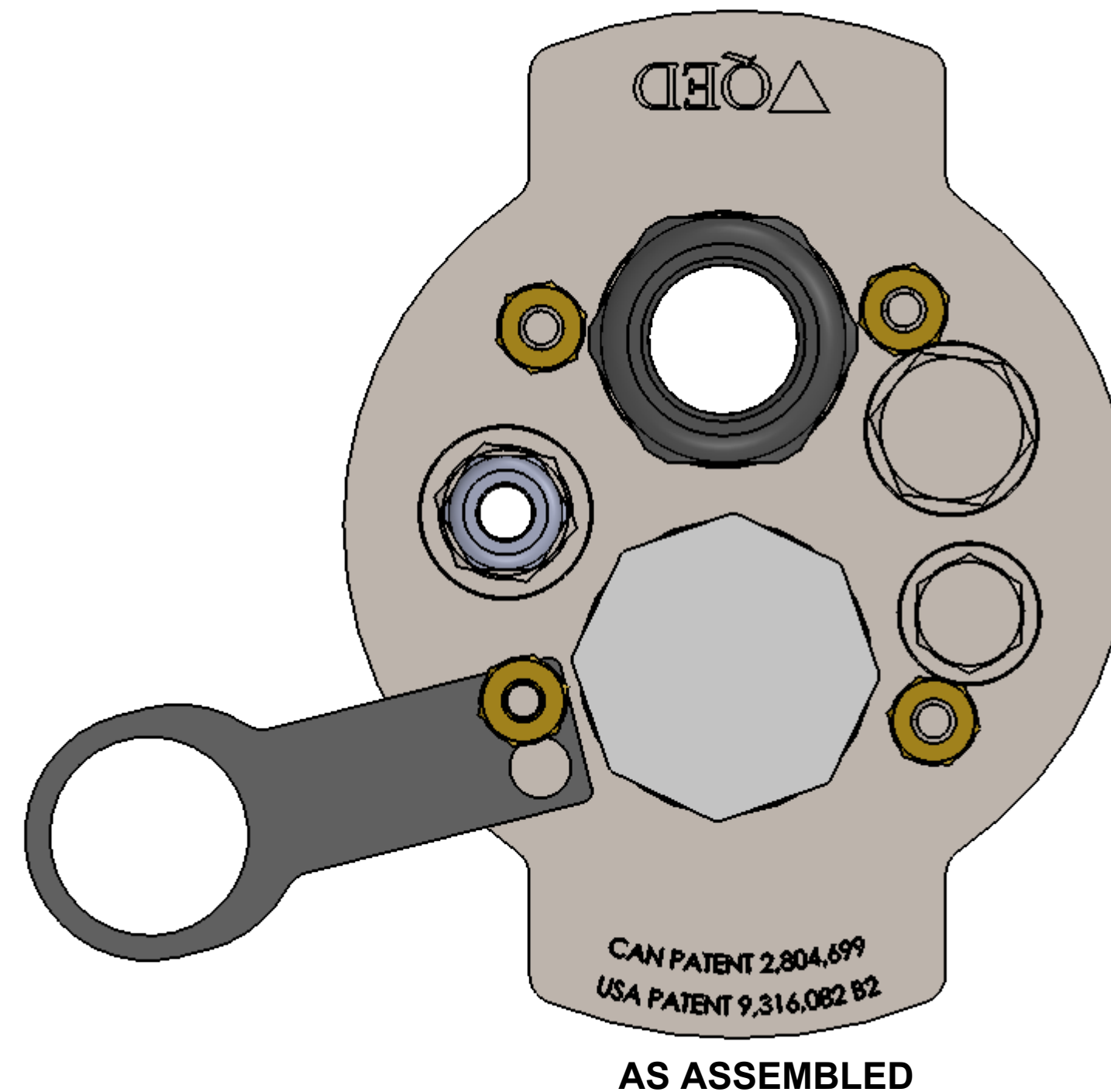

AS ASSEMBLED

NOTE:
 1. TEFLON TAPE ALL PIPE THREADED JOINTS.
 2. CLAMPS ARE PLACED IN A PLASTIC BAG AND SHIP TOGETHER

UNLESS OTHERWISE SPECIFIED, DIMENSIONS ARE IN INCHES AND INCLUDE PLATING REMOVE ALL BURRS	DRAWN BY TR	DATE 01-24-18	 2355 BISHOP CIRCLE W, DEXTER, MI. 48130
	CHECKED BY -	DATE -	
TOLERANCES XX +/- .01 FRACT +/- 1/64 XXX +/- .005 ANGLES +/- 1/2 OTHER TOLERANCES AS SPECIFIED	APPROVED BY -	DATE -	TITLE WELL SEAL 6" 5-PORT FOR APS W/1.25 & 1/2 OD T COMP FTGS EXH IN
NEXT ASSY -	MATERIAL -	DWG. NO. AP306231	REV. A
USED ON -	FINISH -	SCALE 1:4	SHEET 1 OF 1