

THE INFORMATION CONTAINED IN THIS DRAWING IS THE SOLE PROPERTY OF Q.E.D. ENVIRONMENTAL ANY REPRODUCTION IN PART OR WHOLE WITHOUT THE WRITTEN PERMISSION OF Q.E.D. ENVIRONMENTAL IS PROHIBITED.

REVISIONS					
REV.	DESCRIPTION	ECO #	DRAWN BY	CHECKED BY	DATE
-	INITIAL RELEASE	4050	TR	MTM	3/15/2018

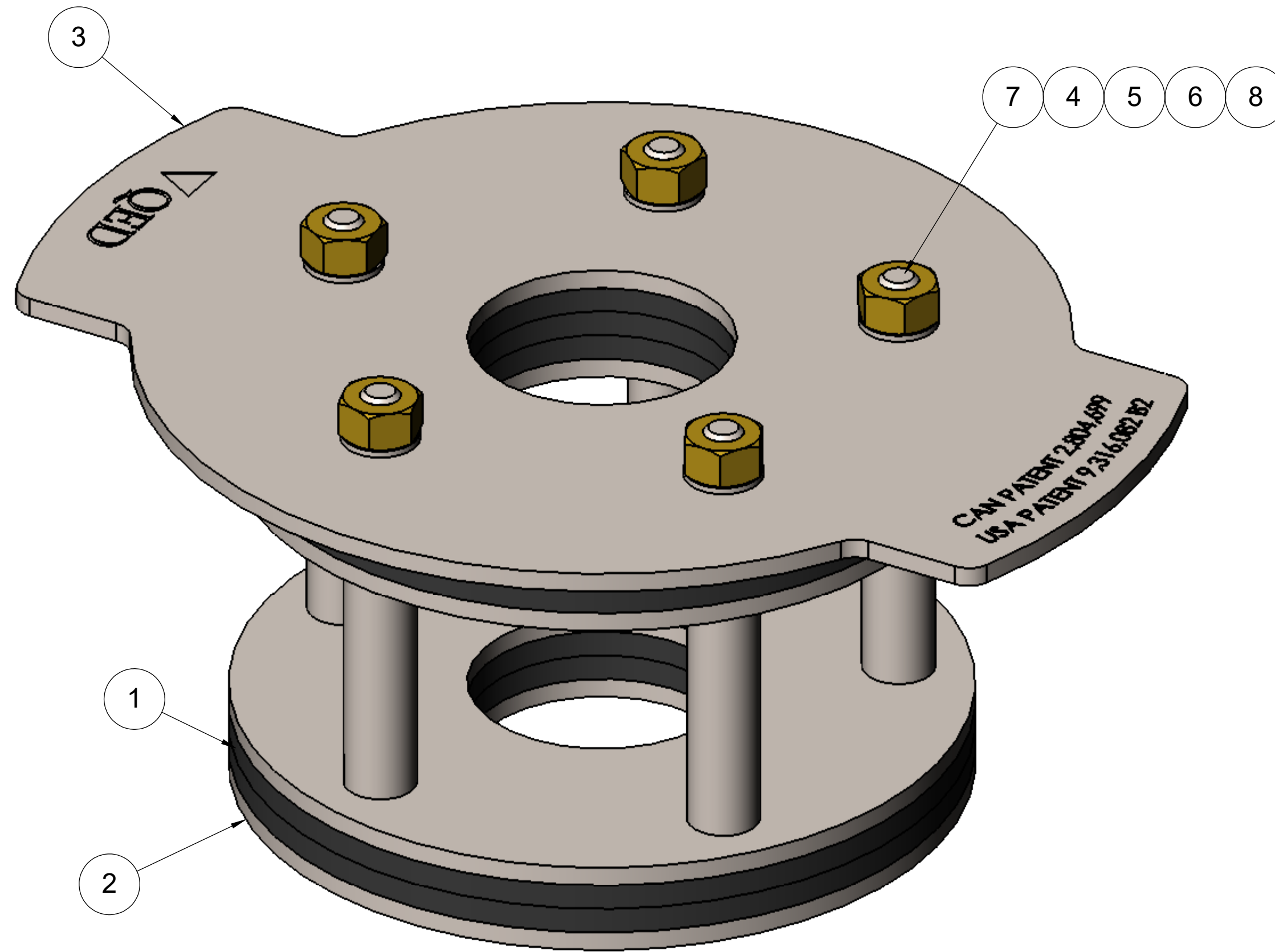

NOTES:

1. TIGHTEN THE HEX NUTS DOWN JUST ENOUGH SO THE PLATES AND GASKETS DO NOT MOVE.
2. RETAINING WASHER IS PLACED BETWEEN THE BOTTOM PLATE AND THE LOWEST RUBBER GASKET.

ITEM	PART #	DESCRIPTION	QTY.
1	DR11-821-1-GA	DR11-821-1 GASKET	5
2	DR11-821-1-CP	DR11-821-1 CLAMP PLATE	3
3	DR11-821-1-TP	DR11-821-1 TOP PLATE	1
4	N38	Hex Nut 3/8-16 Brass	5
5	W38	Flat Washer 3/8	5
6	S38	Spacer	5
7	CB38	Carriage Bolt	5
8	RW38	Retaining Washer	5

UNLESS OTHERWISE SPECIFIED, DIMENSIONS ARE IN INCHES AND INCLUDE PLATING REMOVE ALL BURRS	DRAWN BY TR	DATE 3/15/18	 QED Environmental Systems 2355 BISHOP CIRCLE W, DEXTER, MI. 48130
	CHECKED BY MTM	DATE 4/4/18	
TOLERANCES XX +/- .01 FRACT +/- 1/64 XXX +/- .005 ANGLES +/- 1/2 OTHER TOLERANCES AS SPECIFIED	APPROVED BY -	DATE -	TITLE 8" DR11 WELL SEAL WITH 2" GAS PORT ONLY
	NEXT ASSY -	MATERIAL SEE BOOM	DWG. NO. DR11-821-1-WCA
USED ON -	FINISH -	SCALE 1:2	REV. - SHEET 1 OF 1