



# Assembly Guide

Part No. 95183 REV. 9-9-02

*The World Leader in Air Powered Pumps*

For Remediation, Landfills and Ground Water Sampling



*Ground water Sampling • Remediation, Leachate and Condensation Pumps • Floating Layer Recovery Systems • Air Strippers*

QED ENVIRONMENTAL SYSTEMS

P.O. Box 3726 Ann Arbor, MI 48106-3726 USA • 1-800-624-2026 • FAX (734) 995-1170 • info@qedenv.com • www.qedenv.com  
1133 Seventh Street Oakland CA 94607-2601 • 1-800-537-1767 • FAX (510) 444-6789

COPYRIGHT© 2001 QED ENVIRONMENTAL SYSTEMS



## CONTENTS

<b>Topic</b>	<b>Page</b>
<b>MP40 GAS ENGINE / COMPRESSOR ASSEMBLY</b> _____	<b>1</b>
<b>MP40-1 CART ASSEMBLY</b> _____	<b>2</b>
<b>MP40-2 HOSE REEL ASSEMBLY</b> _____	<b>4</b>
<b>QED Warranty</b> _____	<b>8</b>

**MP40 GAS ENGINE / COMPRESSOR ASSEMBLY**

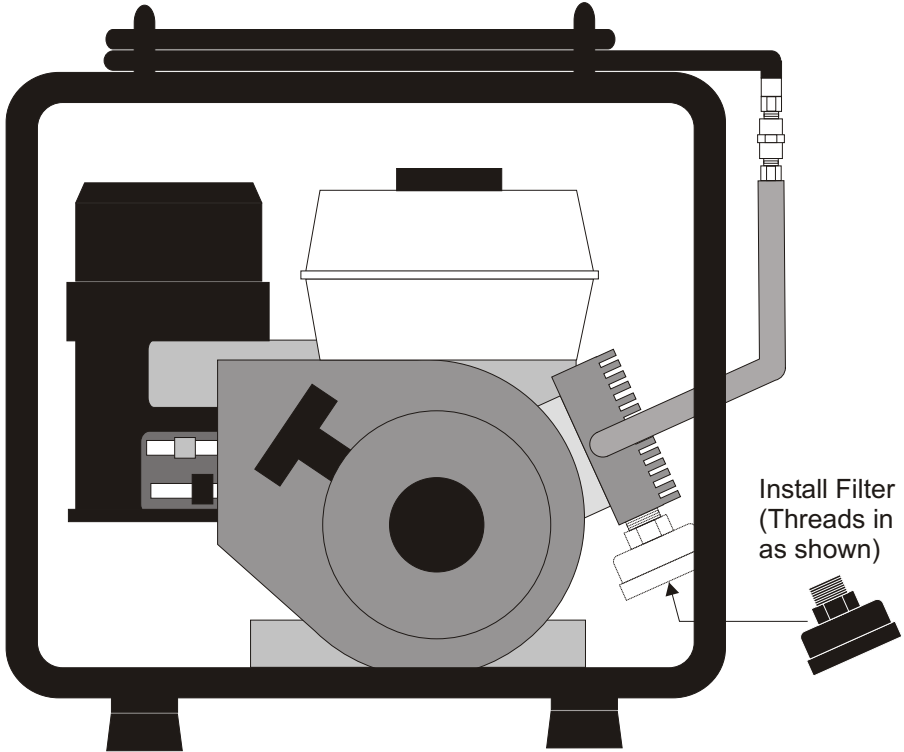

- 1. Attach intake filter to compressor as shown.
- 2. Read and follow engine operating instructions.

## MP40-1 CART ASSEMBLY

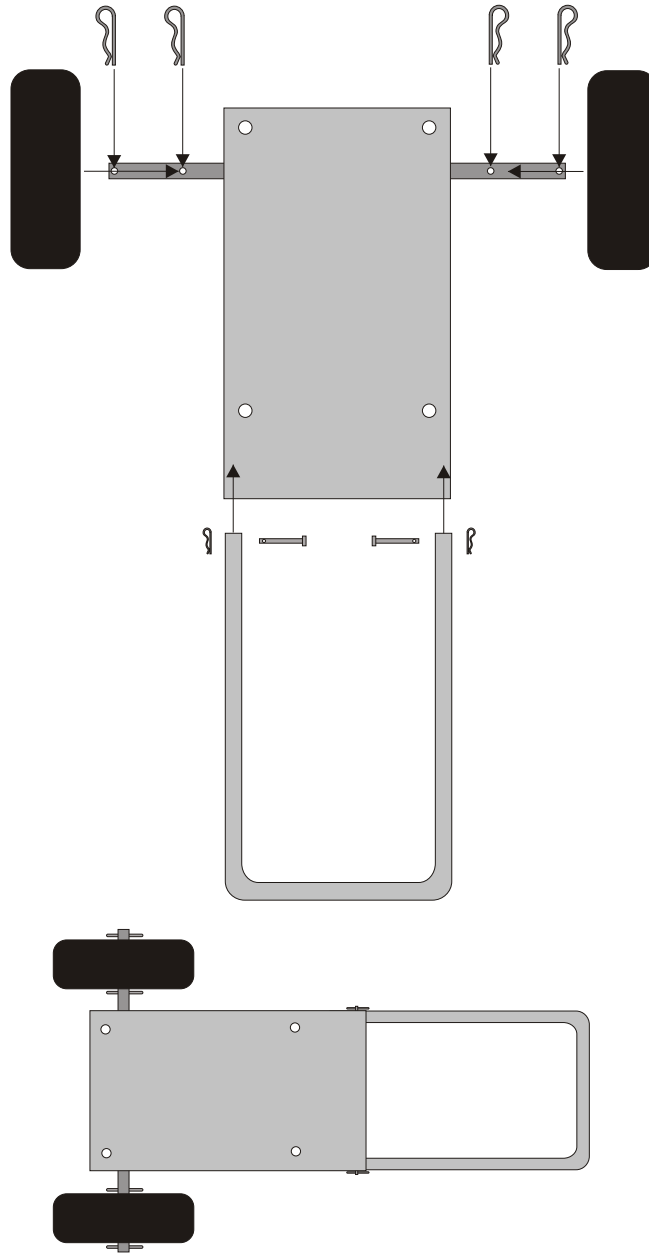

Assemble handle and wheels to cart frame as shown, using cotter clips provided.

## MP40-1 CART ASSEMBLY

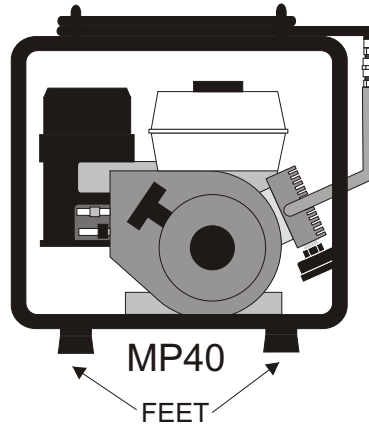

Remove rubber feet (4) from bottom of MP40 Frame.

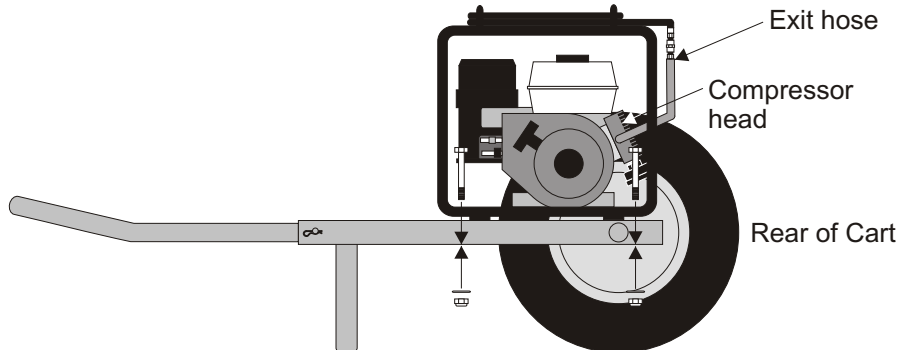

Mount MP40 to frame by removing 4 rubber feet, then bolting the MP40 to the frame with the bolts provided.

**IMPORTANT:** position MP40 with compressor head and exit hose over the cart axle, away from handle end of cart, as shown. The engine can leak oil and be damaged if this is reversed.

## MP40-2 HOSE REEL ASSEMBLY

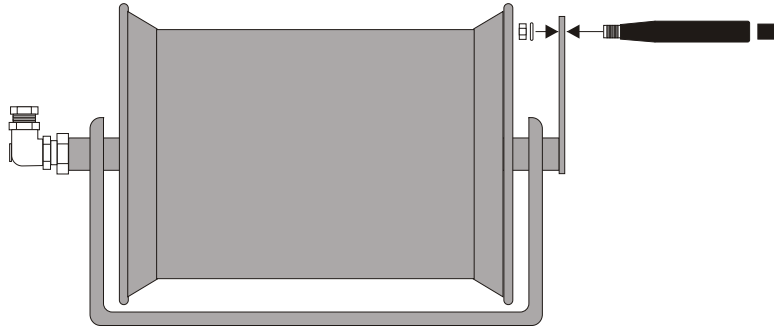

Install reel handle to reel crank arm, using nut and washer provided. Insert plug into end of handle and tighten with allen wrench.

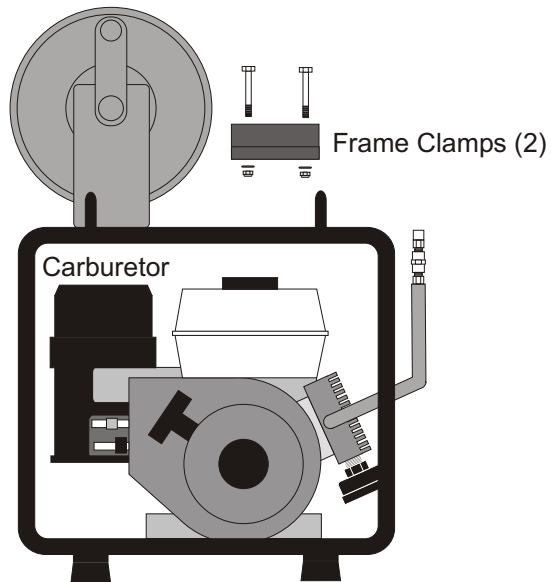

Position Hose Reel on top of MP40 frame as shown, (over carburetor, not over gas tank). Use care to avoid having the reel fall off the frame.

## MP40-2 HOSE REEL ASSEMBLY

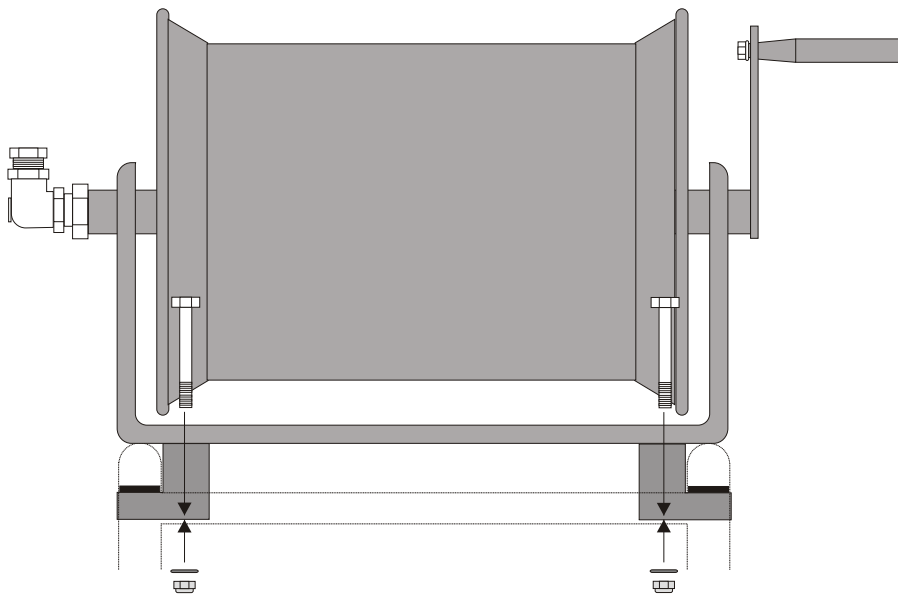

Position frame clamps under reel to grip MP40 frame tube as shown and tighten bolts and nuts securely.



## MP40-2 HOSE REEL ASSEMBLY

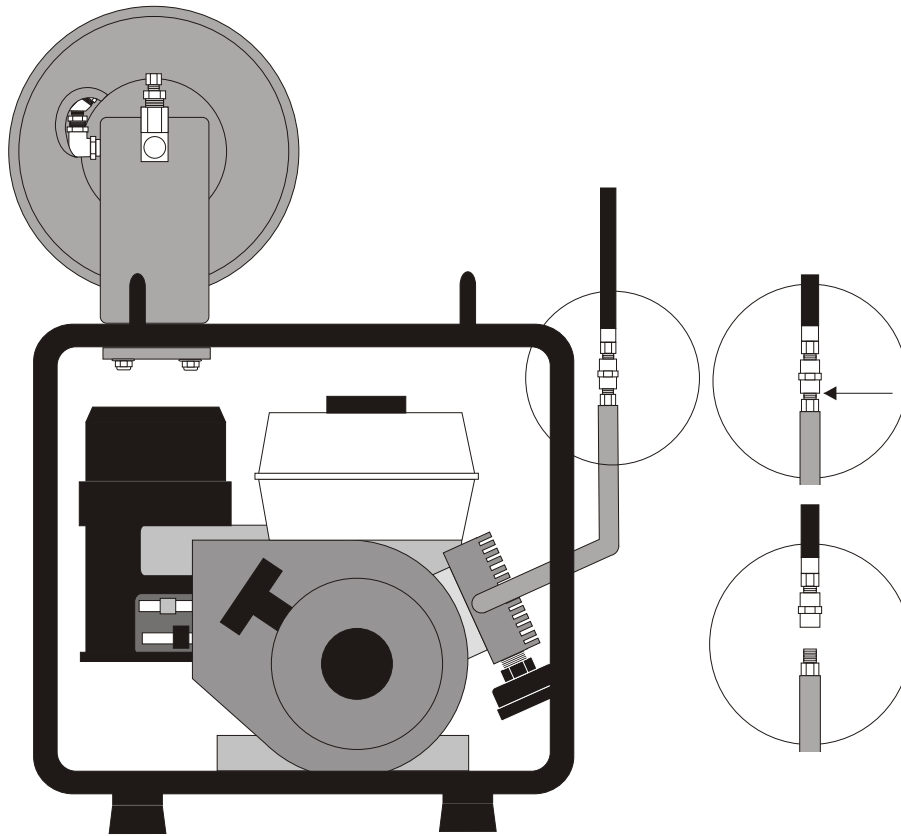

Remove standard 20 foot hose, (Black) from short, orange length of high temperature hose attached to compressor. **DO NOT REMOVE ORANGE HIGH TEMPERATURE HOSE!** *Removing the orange hose from compressor discharge could cause air hose to burst and cause personal injury and/or damage.*

**MP40-2 HOSE REEL ASSEMBLY**

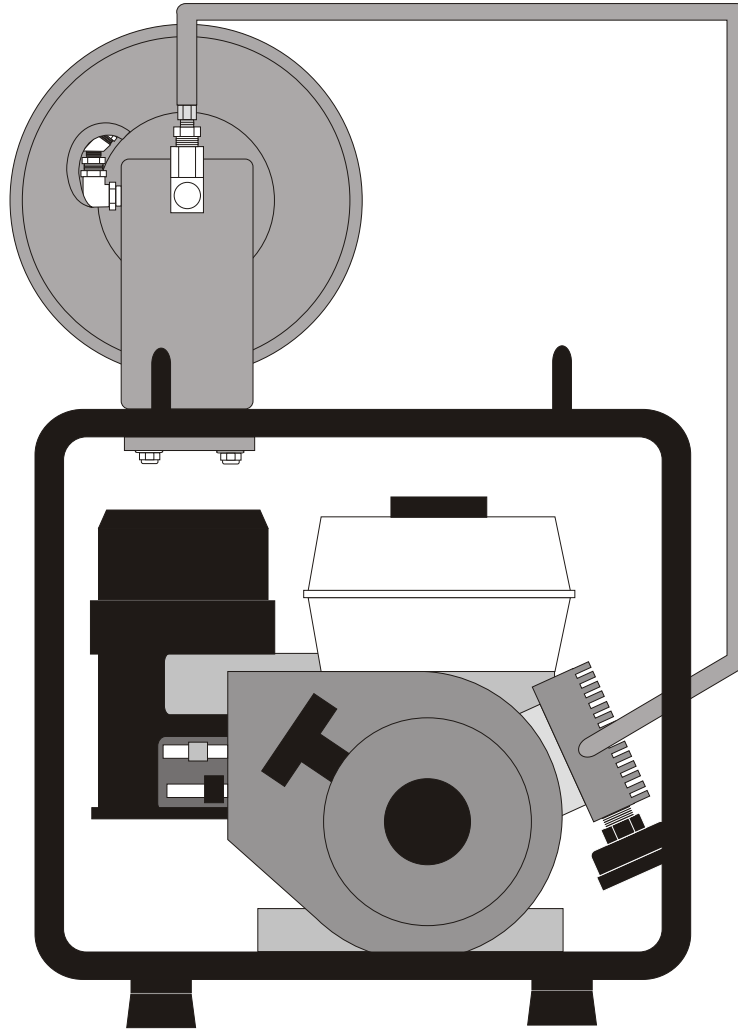

Attach hose reel hose to orange hose.

## WARRANTY

### **QED Monitoring System WARRANTY**

QED ENVIRONMENTAL SYSTEMS, INC. ("QED") warrants to the original purchaser of its products that, subject to the limitations and conditions provided below, the products, materials and/or workmanship shall reasonably conform to descriptions of the products and shall be free of defects in materials and workmanship. Any failure of the products to conform to this warranty will be remedied by QED in the manner provided herein.

This warranty shall be limited to the duration and the conditions set forth below. Warranty duration is calculated from the original date of purchase.

1. Dedicated-Use System Products 10-year warranty on dedicated bladder pumps equipped with QED inlet screens, and purge pumps used in periodic, non-continuous groundwater sampling (up to 52 samples events per year.) All other components, equipment and accessories are warranted for one year.
2. Portable-Use Systems - Controllers and Water Level Meters are warranted for one year. Hose reels, pumps and caps are warranted for ninety (90) days. Tubing and Purge Mizers are covered by a ninety-(90) day material and workmanship warranty. There will be no warranty for application on tubing and Purge Mizers when used as part of a Portable System.
3. Separately Sold Parts and Spare Parts Kit - Separately sold parts and spare parts are warranted for ninety (90) days. Repairs performed by QED are warranted for ninety (90) days from date of repair or for the full term of the original warranty, whichever is longer.

Buyers' exclusive remedy for breach of said warranty shall be as follows: if, and only if, QED is notified in writing within the applicable warranty period of the existence of any such defect in the said products, and QED upon examination of any such defects, shall find the same to be within the term of and covered by the warranty running from QED to Buyer, QED will, at its option, as soon as reasonably possible, replace or repair any such product, without charge to Buyer. If QED for any reason, cannot repair a product covered hereby within four (4) weeks after receipt of the original Purchaser's/Buyer's notification of a warranty claim, then QED's sole responsibility shall be, at its option, either to replace the defective product with a comparable new unit at no charge to the Buyer, or to refund the full purchase price. In no event shall such allegedly defective products be returned to QED without its consent, and QED's obligations of repair, replacement or refund are conditioned upon the Buyer's return of the defective product to QED.

IN NO EVENT SHALL QED ENVIRONMENTAL SYSTEMS, INC. BE LIABLE FOR CONSEQUENTIAL OR INCIDENTAL DAMAGES FOR BREACH OF SAID WARRANTY.

The foregoing warranty does not apply to major sub-assemblies and other equipment, accessories, and parts manufactured by others, and such other parts, accessories, and equipment are subject only to the warranties, if any, supplied by the respective manufacturers. QED makes no warranty concerning products or accessories not manufactured by QED. In the event of failure of any such product accessory, QED will give reasonable assistance to Buyer in obtaining from the respective manufacturer whatever adjustments is reasonable in light of the manufacturer's own warranty.

THE FOREGOING WARRANTY IS IN LIEU OF ALL OTHER WARRANTIES, EXPRESSED, IMPLIED OR STATUTORY (INCLUDING BUT NOT LIMITED TO THE WARRANTIES OF MERCHANTABILITY AND FITNESS FOR A PARTICULAR PURPOSE). WHICH OTHER WARRANTIES ARE EXPRESSLY EXCLUDED HEREBY, and of any other obligations or liabilities on the part of QED, and QED neither assumes nor authorizes any person to assume for it any other obligation or liability in connection with the said products, materials and/or workmanship.

It is understood and agreed that QED shall in no event be liable for incidental or consequential damages resulting from its breach of any of the terms of this agreement, not for special damages, nor for improper selection of any product described or referred to for a particular application.

This warranty will be void in the event of unauthorized disassembly of component assemblies. Defects in any equipment that result from abuse, operation in any manner outside the recommended procedures, use and applications other than for intended use, or exposure to chemical or physical environmental beyond the designated limits of materials and construction will also void this warranty. QED shall be released from all obligations under all warranties if any product covered hereby is repaired or modified by persons other than QED's service personnel unless such repair by others is made with the written consent of QED.

## WARRANTY

### QED Monitoring System WARRANTY (cont.)

This warranty will be void in the event of unauthorized disassembly of component assemblies. Defects in any equipment that result from abuse, operation in any manner outside the recommended procedures, use and applications other than for intended use, or exposure to chemical or physical environmental beyond the designated limits of materials and construction will also void this warranty. QED shall be released from all obligations under all warranties if any product covered hereby is repaired or modified by persons other than QED's service personnel unless such repair by others is made with the written consent of QED.

If any product covered hereby is actually defective within the terms of this warranty, Purchaser must contact QED for determination of warranty coverage. If the return of a component is determined to be necessary, QED will authorize the return of the component, at owner's expense. If the product proves not be defective within the terms of this warranty, then all costs and expenses in connection with the processing of the Purchaser's \ claim and all costs for repair, parts and labor as authorized by owner hereunder shall be borne by the Purchaser.

#### RESPONSIBILITY OF THE PURCHASER

The original Purchaser's sole responsibility in the instance of a warranty claim shall be to notify QED of the defect, malfunction, or other manner in which the terms of this warranty are believed to be violated. You may secure performance of obligations hereunder by contacting the Customer Service Department of QED and:

1. Identifying the product involved (by model or serial number or other sufficient description that will allow QED to determine which product is defective).
2. Specifying where, when, and from whom the product was purchased.
3. Describing the nature of the defect or malfunction covered by this warranty.
4. Sending the malfunction component, after authorization by QED to:

**QED Environmental Systems Inc.**  
**2355 Bishop Circle West**  
**Dexter, MI 48130**  
**(800) 624-2026**  
**(734) 995-2547**  
[www.qedenv.com](http://www.qedenv.com)  
[info@qedenv.com](mailto:info@qedenv.com)