

E-Z TRAY EZ-8.4HF

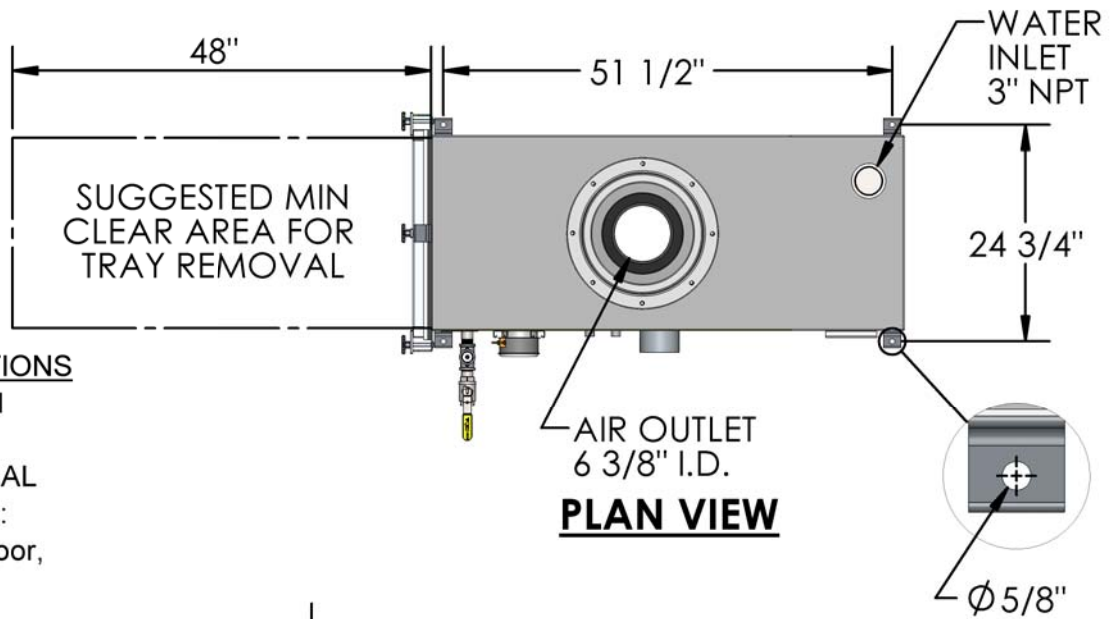

PLAN VIEW

GENERAL SPECIFICATIONS

- Max. flow rate: 120 GPM
- Air flow: 420 CFM
- Sump working vol.: 63 GAL
- Materials of construction: 304SS , polycarbonate door, neoprene gaskets and polyester felt.

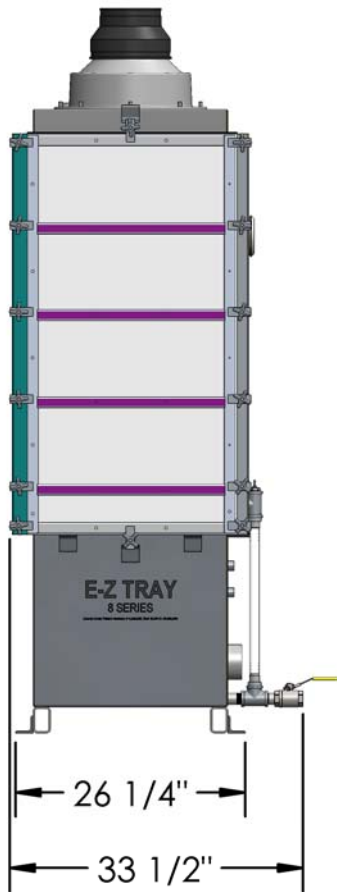

FRONT VIEW

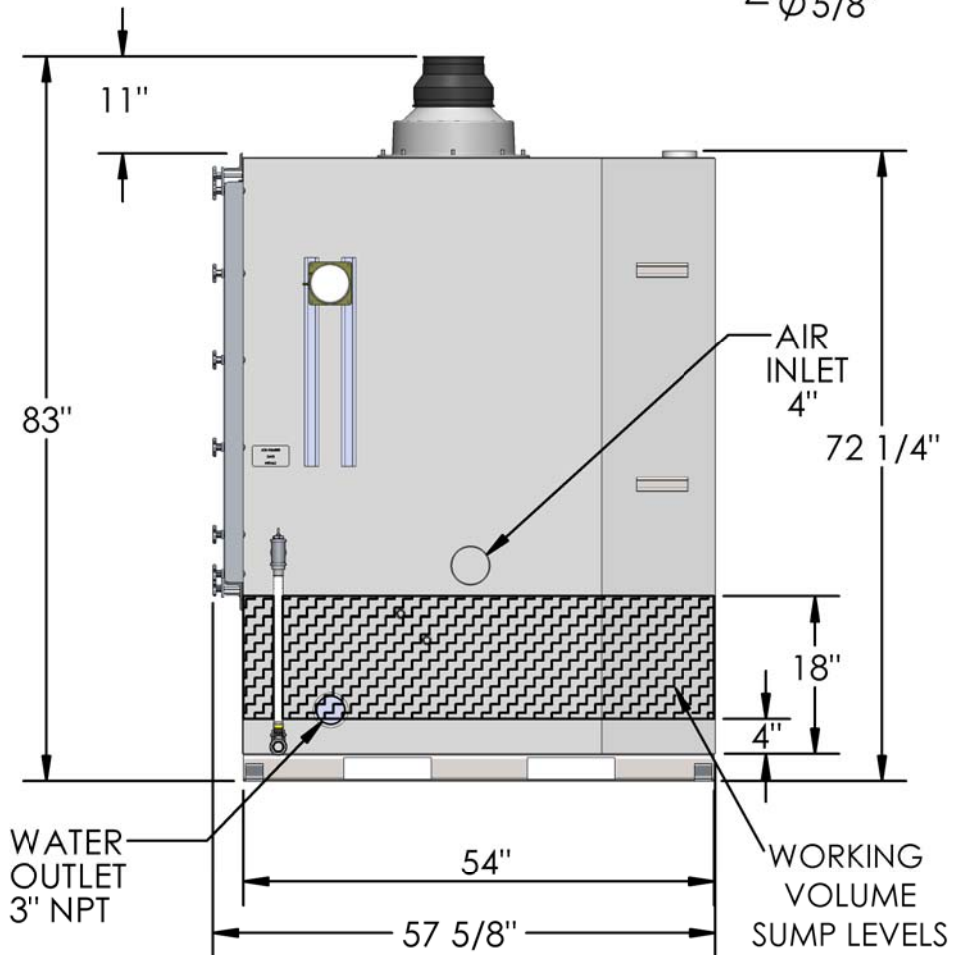

SIDE VIEW

EZ-8.4HF (AIR STRIPPER ONLY)

FOR MORE SPECIFICATIONS CLICK ON:

<http://www.qedenv.com>

NOT TO SCALE, NOT FOR CONSTRUCTION, FOR REFERENCE ONLY
 LICENSED UNDER PATENT # 10,272,356 B2 AND
 MORE U.S. AND NON U.S. PATENTS.



GENERAL SPECIFICATIONS

- Max. flow rate: 120 GPM
- Air flow: 320 CFM
- Sump working vol.: 46 GAL
- Materials of construction: 304SS , polycarbonate door, neoprene gaskets and polyester felt.

SUGGESTED MIN CLEAR AREA FOR TRAY REMOVAL

MIN CLEAR AREA IN FRONT OF PANEL

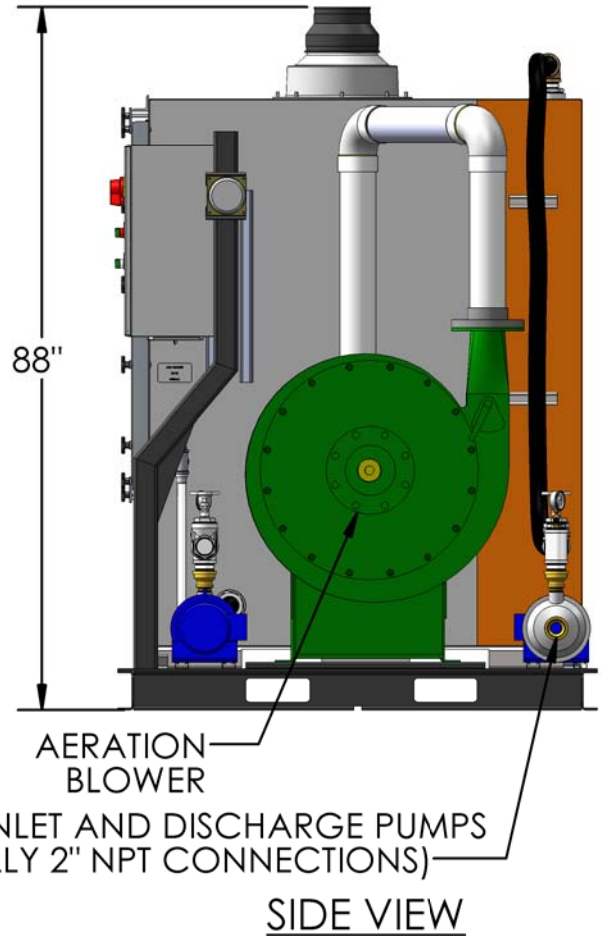
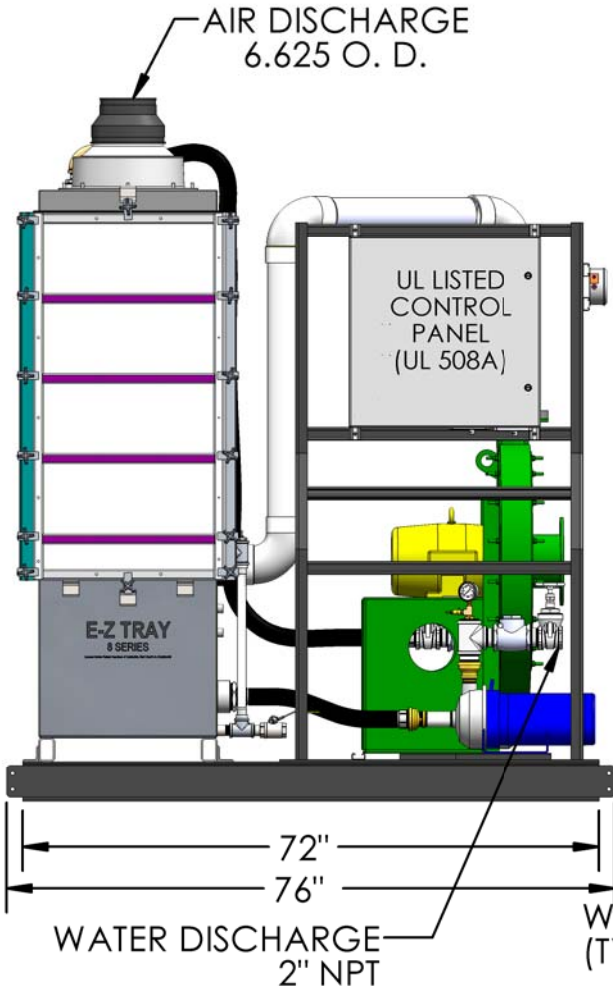
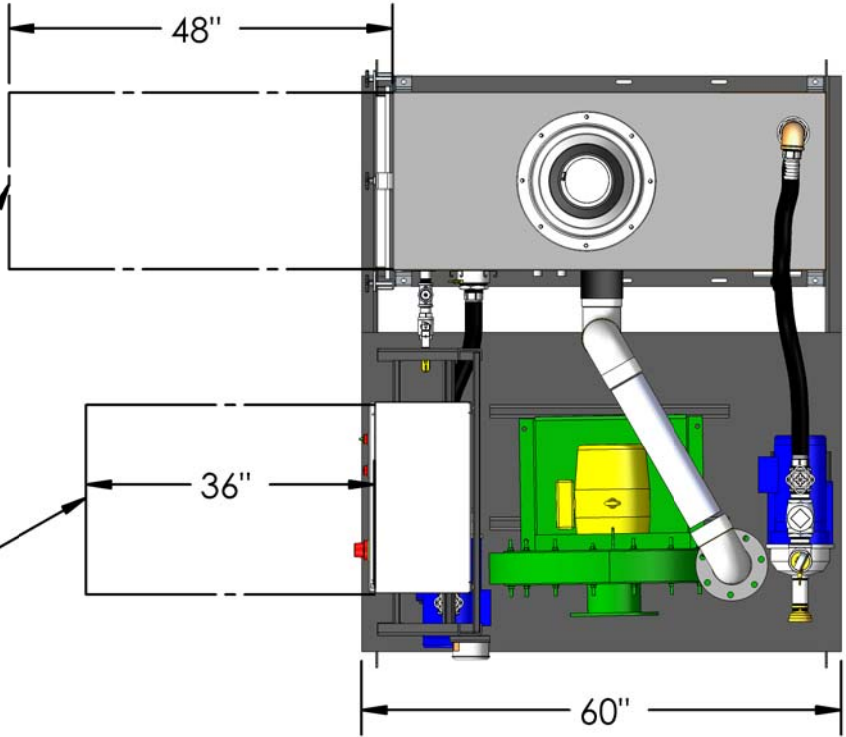

EXAMPLE OF A SKID SYSTEM WITH CONTROL PANEL, PUMPS, AND BLOWER CONTACT QED FOR INFORMATION ON ALL OPTIONS. NOT TO SCALE, NOT FOR CONSTRUCTION, FOR REFERENCE ONLY LICENSED UNDER PATENT # 10,272,356 B2 AND MORE U.S. AND NON U.S. PATENTS.